

DYNO[®]-MILL UBM UNIVERSAL BEAD MILL

Efficient dispersion and ultra-fine grinding solutions for your products



RELIABLE PARTNER FOR YOUR PROCESS

More than 60 years of experience and leading technologies incorporated in one series: DYNO®-MILL Universal Bead Mill (UBM). The new generation of agitator bead mills from WAB covers the entire range from dispersion to ultra-fine grinding and production of small and large product quantities, thus meeting industry's requirements for high efficiency, reliability and lowest total cost of ownership. The new series also combines optimised maintenance intervals and simple operation with the technically comprehensive experience of WAB Customer Services – something that users also appreciate.

The large screen of the newly developed DYNO®-MILL UBM series enables the processing of highly viscous products with high throughput rates. One of the strengths of the agitator bead mill is the extremely even distribution of grinding beads in the active grinding chamber. This allows stable and efficient process parameters to be easily determined for both pass and circulation mode.



SCALABLE AND COST-EFFECTIVE

The DYNO®-MILL UBM is a fully scalable series with a grinding chamber volume of 0.5 litres to 100 litres. The innovative design of the new series enables quick and reliable transfer from the lab to the field.

The high wear resistance of the DYNO®-MILL UBM results in extended maintenance intervals and reduced maintenance costs. In conjunction with the technically proficient and reliable WAB Customer Services, this mill generation guarantees optimum machine availability.

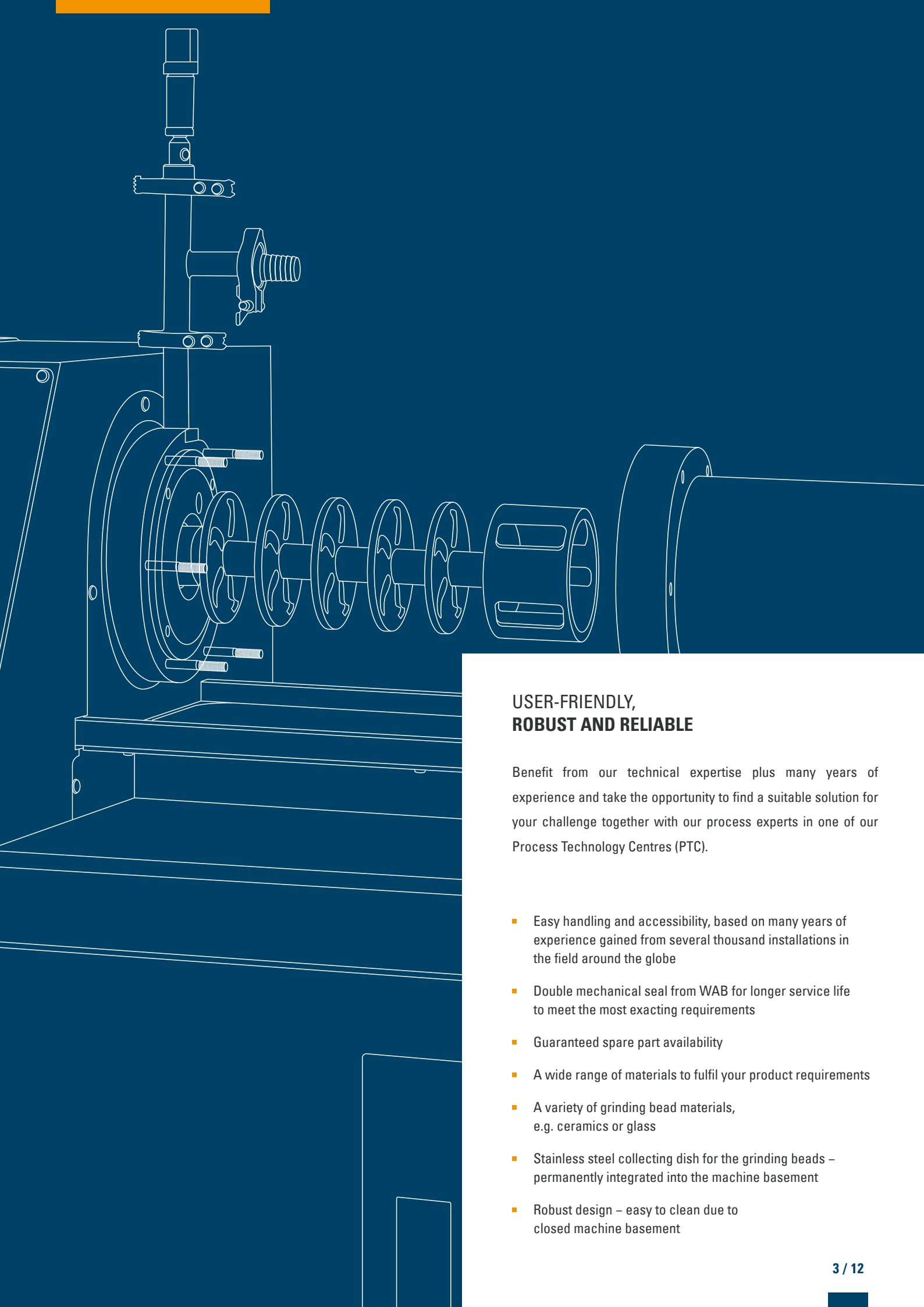

USER-FRIENDLY, ROBUST AND RELIABLE

Benefit from our technical expertise plus many years of experience and take the opportunity to find a suitable solution for your challenge together with our process experts in one of our Process Technology Centres (PTC).

- Easy handling and accessibility, based on many years of experience gained from several thousand installations in the field around the globe
- Double mechanical seal from WAB for longer service life to meet the most exacting requirements
- Guaranteed spare part availability
- A wide range of materials to fulfil your product requirements
- A variety of grinding bead materials, e.g. ceramics or glass
- Stainless steel collecting dish for the grinding beads – permanently integrated into the machine basement
- Robust design – easy to clean due to closed machine basement



LONG SERVICE LIFE DUE TO CONSISTENT QUALITY

Our agitator bead mill meets the highest requirements in terms of quality and wear resistance.

- Precisely defined product and bead flow
- High wear resistance, thus reducing maintenance costs
- Optimised agitator design for longer service life



**SCAN THE CODE
FOR MORE INFORMATION!**

www.wab-group.com/en/products/dyno-mill-ubm

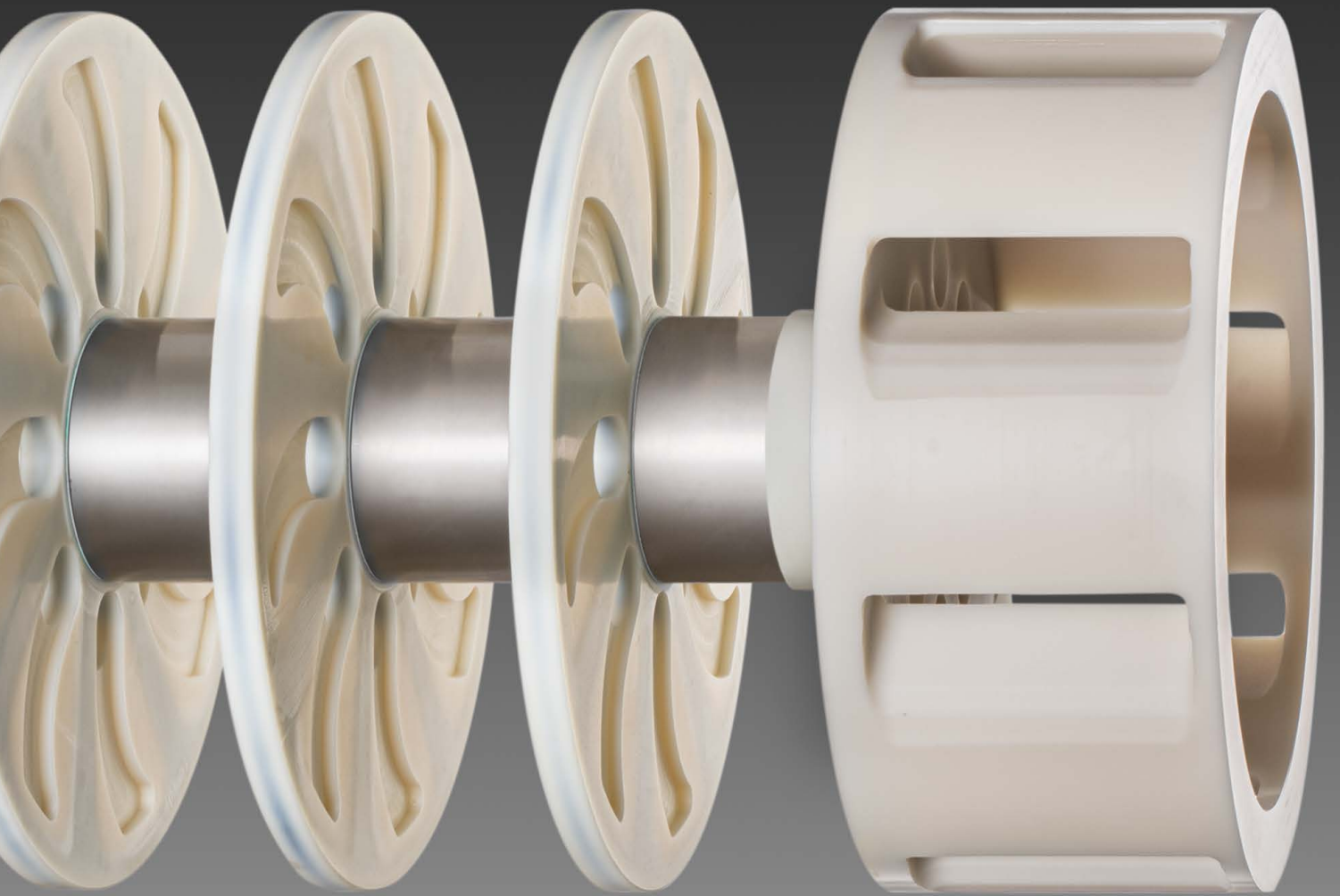

NEW GENERATION OF AGITATOR BEAD MILLS DYNO[®]-MILL UBM SERIES

Within the diverse range of mills from WAB, you are guaranteed to find the ideal model for your most demanding product. Our many years of experience help us to perfectly meet your process needs in projects with different and special requirements. On request, we can also carry out the Factory Acceptance Test (FAT) or the Site Acceptance Test (SAT) together with you on your own premises.

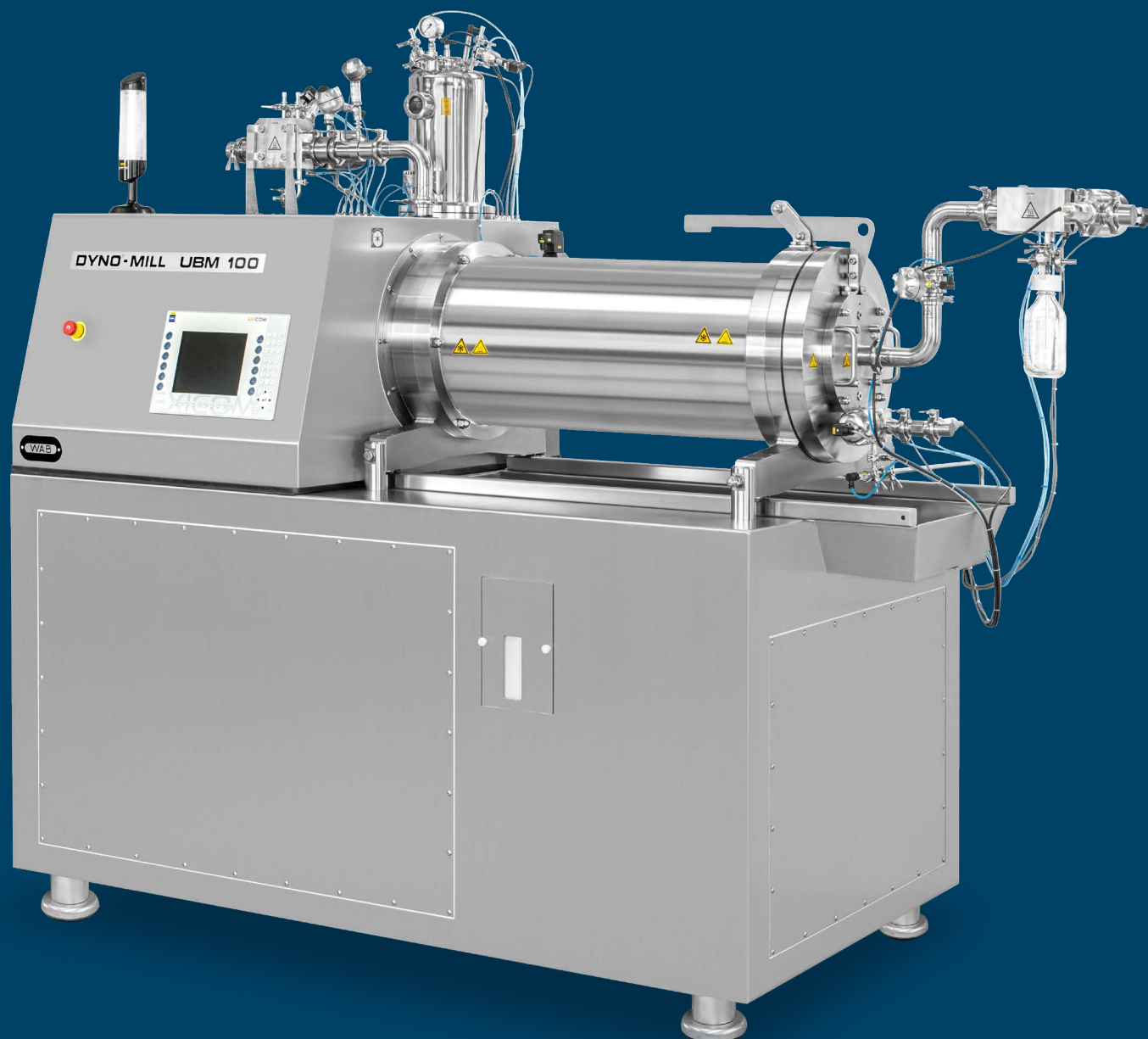

DYNO[®]-MILL UBM

MILLING PRINCIPLE

The new generation of DYNO[®]-DISC BC agitator discs was specially developed for this series. They feature unique bead channels combined with a closed outer contour. The bead channels ensure efficient acceleration of the grinding beads along a precisely defined path. During operation, each of the bead channels creates two efficient grinding circuits between the DYNO[®]-DISC BC agitator discs that work in opposite directions. The outer contour of the new DYNO[®]-DISC BC is completely closed. The grinding beads therefore remain between the agitator discs and are distributed evenly throughout the active grinding chamber. This ensures the efficient utilisation of the bed of grinding beads in the DYNO[®]-MILL UBM. The DYNO[®]-DISC BC agitator discs are designed for excellent wear resistance and constantly guarantee high performance. At the same time, they reduce the maintenance costs of the DYNO[®]-MILL UBM series.

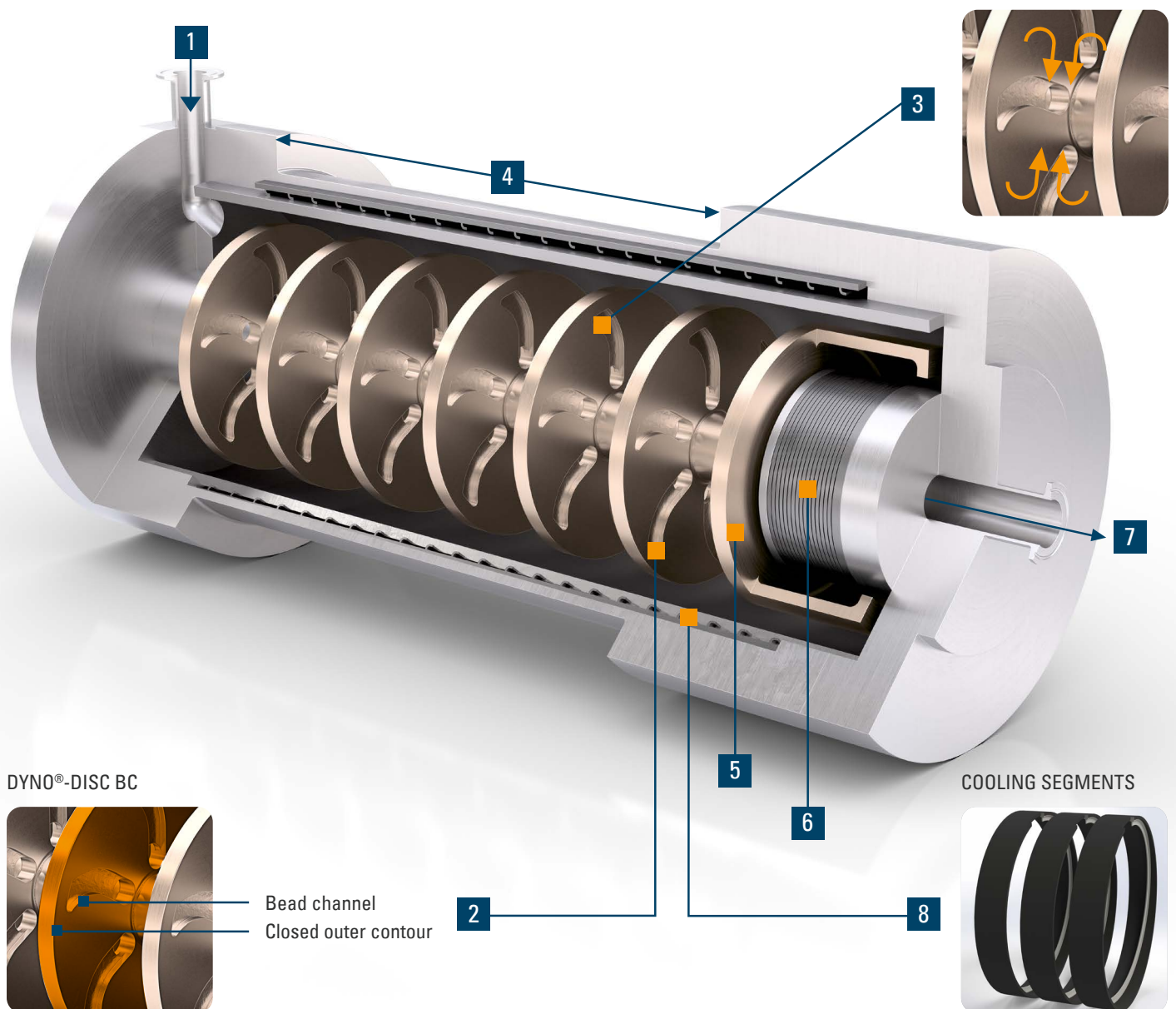

DYNO[®]-DISC BC

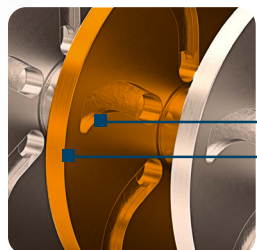

Bead channel
Closed outer contour

COOLING SEGMENTS



- 1 Product inlet
- 2 DYNO[®]-DISC BC (Bead Channel)
- 3 Grinding circuits that operate in opposite directions

- 4 Even distribution of the grinding beads in the active grinding chamber
- 5 DYNO[®]-ROTOR BS (Bead Separation)

- 6 Screen for high throughputs
- 7 Product outlet
- 8 Cooling segments

THE KEY ADVANTAGES OF DYNO[®]-MILL UBM

Unique grinding principle based on the innovative and patented DYNO[®]-DISC BC.

Long service life
of the screen

Suitable for high
throughput rates

Use of grinding beads
between \varnothing 0.2 and 2.5 mm



Wide range of materials
for optimum mill equipment

Appropriate grinding region height
for ergonomic working

Suitable for pass and
circulation mode

Grinding chamber volumes
from 0.5 to 100 litres

Ideally suited for the dispersion and
grinding of highly viscous products

MANY YEARS OF EXPERIENCE IN DIFFERENT FIELDS OF APPLICATION

DYNO®-MILL UBM and DYNO®-MILL UNI LAB are specifically designed for aqueous, solvent-based and contamination sensitive products. Our series is used in a wide range of industries and applications from the lab to production. Throughout the long service life of the individual DYNO®-MILL, users enjoy maximum flexibility and reliable scalability.



Industrial paint



Crop protection



Ink



Battery materials



Coatings



Inkjet



Food & Beverage



Cosmetics



Cell disruption



Pharmaceuticals



DYNO®-MILL UBM 100



DYNO®-MILL UBM 20



DYNO®-MILL UBM 50



DYNO®-MILL UBM 5



DYNO®-MILL UNI LAB

OUR CONTROL SOLUTIONS TO MONITOR YOUR PROCESS

The extensive range of WAB-GROUP® control systems lets us adapt the control solution to your needs.
The ease of use of the individual systems ensures safe and reproducible operation.

WAB VIEW

The WAB VIEW addresses customers who wish to control the machine with graphical assistance and export the production data to their in-house process control system or use the machine with remote operation.

- WAB VIEW with graphical 7" touch screen
- User access level with password protection
- Data export via Ethernet
- Local and remote operation possible
- Recipe management (99 recipes) and report printout via USB interface



WAB VIEW PRO

Our premium solution enables users a smooth production process and, together with the WAB SCADA, a constant backup of the data.

- WAB VIEW PRO with graphical 10" touch screen and function buttons
- User access level with password protection
- Graphical trend overview (product temperature and pressure, peripheral speed, etc.)
- Data export via Ethernet
- Prepared for WAB SCADA (according to 21 CFR Part 11) with electronic signatures and records
- Local and remote operation possible
- Recipe management (99 recipes)

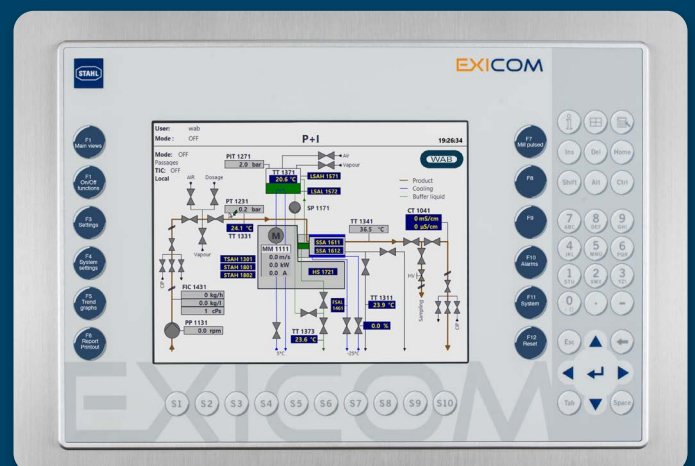



**SCAN THE CODE
FOR MORE INFORMATION!**

www.wab-group.com/en/products/dyno-mill-ubm

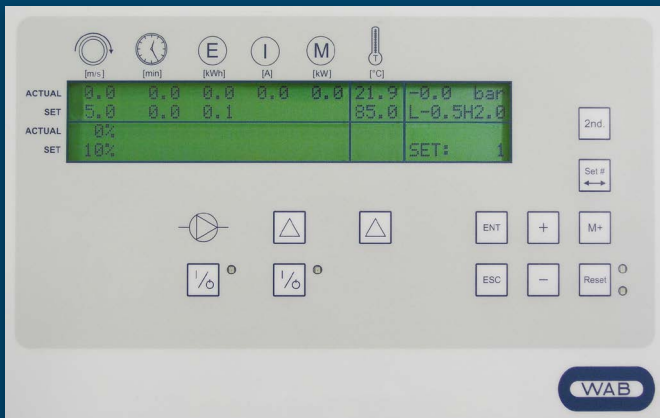

WAB CONTROL

Plug-and-play solution to control and record your process. It promotes fast and easy data export to Microsoft Excel using the integrated WAB data software.

- USB interface for data transmission to the WAB CONTROL PC software
- Process control and automatic stop functions depending on energy input or time lapse
- Recipe management (10 recipes)
- Only available for non-explosion-protected machines

WAB BASIC

Our proven, uncomplicated solution for your process.

- Easy to control
- Cost efficient
- Straightforward, simple operation
- Frequency converter available for mill and product pump motors



WAB-GROUP® ENTITIES

WAB-GROUP® is your reliable and global partner. With our local sites and technical specialists on site, we are happy to be at your service as a proficient mechanical engineering company and proven process expert. In our production facilities on four continents, we manufacture to the highest quality standards and assure professional and comprehensive support.

Willy A. Bachofen AG

Junkermattstrasse 11
P.O. Box 944
4132 Muttenz 1
Switzerland
+41 61 6867 100
wab@wab-group.com
www.wab-group.com

WAB US Corp.

3 Pearl Court, Suite E
Allendale, NJ 07401
USA
+1 973 873 9155
wab-us@wab-group.com
www.wab-group.com

Willy A. Bachofen S.à.r.l.

3, rue Paul Henri Spaak
68390 Sausheim
France
+33 389 31 17 00
wab-fr@wab-group.com
www.wab-group.com

Willy A. Bachofen GmbH

Liebigstrasse 16
61130 Nidderau-Heldenbergen
Germany
+49 6187 9394 0
wab-de@wab-group.com
www.wab-group.com

WAB India Pvt. Ltd.

Plot No. D 36/3B
T.T.C. Industrial Area, Turbhe
Navi Mumbai - 400 705
India
+91 22 613 171 00
wab-in@wab-group.com
www.wab-group.com

WAB Machinery (Shenzhen) Co., Ltd.

Room 1710, Kerry Everbright City, Phase 1
No. 218 Tianmu Road West
Jing'an District, Shanghai - 200070
China
+86 21 6380 6481
wab-cn@wab-group.com
www.wab-group.com

WAB Machinery (Shenzhen) Co., Ltd.

Unit 102, Floor 1, Plant Building 1
Everbrite Technology Park, Mingqing Road
Longhua District, Shenzhen - 518109
China
+86 755 2813 5108
wab-cn@wab-group.com
www.wab-group.com

WAB Israel Corp. Ltd.

17th floor, B.S.R 2 Building
1 Ben Gurion Str., Bnei Brak 5120149
Israel
+972 3 6142303
wab-il@wab-group.com
www.wab-group.com

Contact our WAB-GROUP® locations or one of the numerous partners within our strong network.



**SCAN THE CODE
FOR MORE INFORMATION!**

www.wab-group.com